

Version with Erowa Power Chuck P

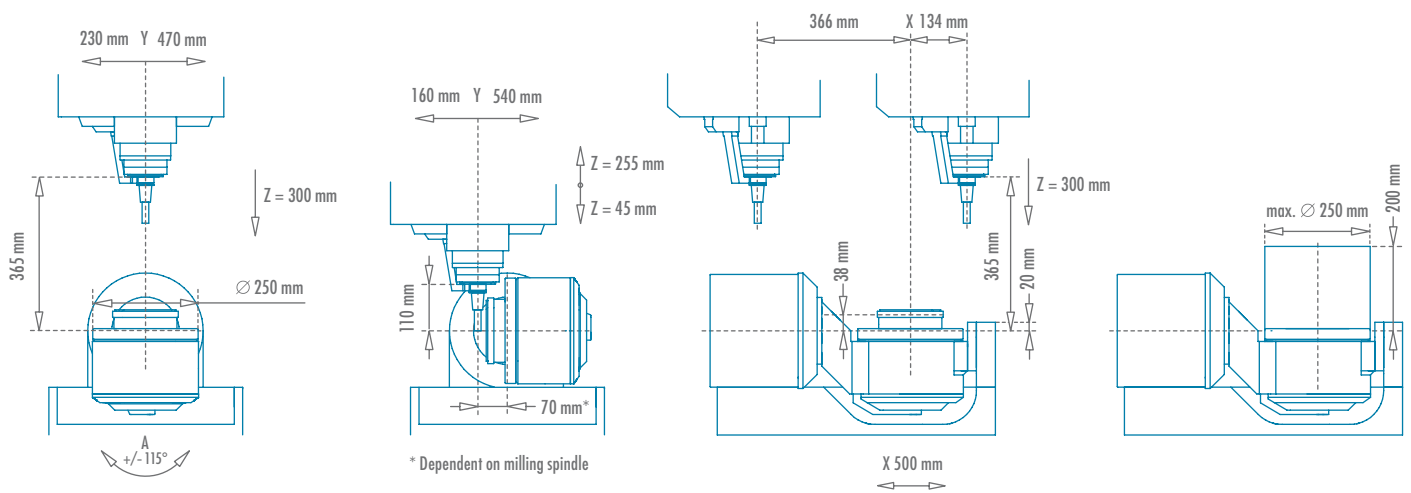

Stroke position
RXP501DS

Subject to change
Revision 19/05